



Integrated chemiluminescence-based lab-on-chip for detection of life markers in extraterrestrial environments



Augusto Nascetti^{a,*}, Mara Mirasoli^{b,*}, Elisa Marchegiani^b, Martina Zangheri^b,
Francesca Costantini^a, Alessandro Porchetta^c, Lorenzo Iannascoli^a, Nicola Lovecchio^d,
Domenico Caputo^d, Giampiero de Cesare^d, Simone Pirrotta^e, Aldo Roda^b

^a School of Aerospace Engineering, Sapienza University of Rome, Via Salaria 851, 00138 Rome, Italy

^b Department of Chemistry "Giacomo Ciamician", Alma Mater Studiorum - University of Bologna, via Selmi 2, Bologna, Italy

^c Chemistry Department, University of Rome, Tor Vergata, Via della Ricerca Scientifica, 00133 Rome, Italy

^d Department of Information Engineering, Electronics And Telecommunications, Sapienza University of Rome, via Eudossiana 18, 00185 Rome, Italy

^e Italian Space Agency, Via del Politecnico, 00133 Roma, Italy

ARTICLE INFO

Keywords:

Lab on chip
Life markers
Astrobiology
Thin film photosensors
Chemiluminescence
Adenosine triphosphate

ABSTRACT

The detection of life markers is a high priority task in the exploration of the Solar System. Biochips performing in-situ multiplex immunoassays are a very promising approach alternative to gas chromatography coupled with mass spectrometry. As part of the PLEIADES project, we present the development of a chemiluminescence-based, highly integrated analytical platform for the detection of biomarkers outside of the Earth. The PLEIADES device goes beyond the current lab-on-chip approaches that still require bulky external instrumentation for their operation. It exploits an autonomous capillary force-driven microfluidic network, an array of thin-film hydrogenated amorphous silicon photosensors, and chemiluminescence bioassays to provide highly sensitive analyte detection in a very simple and compact configuration. Adenosine triphosphate was selected as the target life marker. Three bioassay formats have been developed, namely (a) a bioluminescence assay exploiting a luciferase mutant with enhanced thermal and pH stability and (b and c) binding assays exploiting antibodies or functional nucleic acids (aptamers) as biospecific recognition elements and peroxidase or DNazymes as chemiluminescence reporters. Preliminary results, showing limits of detection in the nanomolar range, confirm the validity of the proposed approach.

1. Introduction

The search for organic compounds in the surface or sub-surface of planets, satellites or other small bodies is a major challenge in extraterrestrial exploration. Up to date, space missions dedicated to the search for biosignatures of extant or extinct life mainly relied on pyrolytic extraction of volatile compounds and their detection by gas chromatography (GC) coupled with mass spectrometry (MS). However, pyrolysis-GC-MS mainly detects simple organic molecules (e.g., aminoacids, sugars, nucleobases, carboxylic acids) that can be present in space environments also as products of abiotic processes. In addition, only very recently some organic molecules could be detected and identified in exploration missions (Eigenbrode et al., 2018). Unsuccessful previous analyses can be probably ascribed to targets decomposition caused by complex interactions between analytes and matrix components occurring at high volatilization temperatures for

pyrolysis-GC-MS analysis, such as oxidation by perchlorates present on Mars surface (Poinot and Geffroy-Rodier, 2015).

In recent years, scientists have been turning towards gentler bioanalytical approaches based on immunoassays performed in microfluidic devices, such as the Life Marker Chip (LMC) (Sephton et al., 2013; Sims et al., 2012), or microarrays, such as the Signs Of Life Detector (SOLID) (Parro et al., 2011; Moreno-Paz et al., 2018). A major advantage is the possibility to target biomolecules in a wide range of molecular sizes, from small organic molecules to biopolymers and even cells, thus expanding detection capabilities beyond low-to-mid-molecular-weight organic life markers.

Adenosine 5'-triphosphate (ATP) is a good candidate as the target analyte, basing on the hypothesis that life developed on extraterrestrial environments would follow similar evolutionary principles as in Earth, given that the initial organics inventory, and in some cases the environments, were likely to have been similar (Parnell et al., 2007). ATP

* Corresponding authors.

E-mail addresses: augusto.nascetti@uniroma1.it (A. Nascetti), mara.mirasoli@unibo.it (M. Mirasoli).

<https://doi.org/10.1016/j.bios.2018.08.056>

Received 8 May 2018; Received in revised form 23 August 2018; Accepted 23 August 2018

Available online 25 August 2018

0956-5663/ © 2018 Elsevier B.V. All rights reserved.

is an energy storage/transfer biomolecule, ubiquitous on Earth, that is considered a relevant marker of extant life, as it rapidly degrades in the absence of viable organisms due to the intrinsic instability of its high-energy bonds.

The detection of life markers present at very low concentration requires highly sensitive techniques. Bioaffinity methods based on the use of antibodies as specific recognition elements can guarantee high sensitivity and selectivity and are suitable for their implementation into miniaturized biochips (Pointot and Geffroy-Rodier, 2015). Although relatively high stability of antibodies to cosmic radiations has been reported (Baque et al., 2017), recently nucleic acid aptamers have been proposed as substitutes, taking advantage of their higher stability under harsh conditions (Baque et al., 2011). Aptamers are single-stranded DNA or RNA oligonucleotides (generally 20–70 nucleobases) obtained by the systematic evolution of ligands by exponential enrichment (SELEX) procedure (Ellington and Szostak, 1990; Tuerk and Gold, 1990). DNA aptamers are stable for many years under freeze-dried conditions, while in solution a denaturation-renaturation process (heating/cooling step) allows their regeneration in 30 min. In addition to being employed merely as antibody substitutes, aptamers can be exploited to produce nucleic acid-based molecular nanoswitches, suitable for real-time molecular sensing in complex environments and exploiting DNAzyme-mediated catalysis to reach high target detectability (Ma et al., 2017). Enzyme-based assays are also worth being explored for life marker detection, as they are well established in clinical chemistry analyses and they would enable enlarging the suite of detectable molecules to low-molecular weight compounds, for which antibodies with high binding avidity are not easily obtained.

Taking into account space payloads constraints, such as reduced mass, volume, and power consumption, extremely compact analytical instruments are required. In this context, lab-on-chip devices are extremely attractive for space missions (Roda et al., 2018). However, the vast majority of the proposed lab-on-chip systems, including both commercial and research devices, can be referred as “chip-in-a-lab” instead (Mohammed et al., 2015), since operation of microfluidic chips requires bulky ancillary equipment such as fluidic pumps, high current power supplies, signal acquisition devices (microscopes, spectrometers, etc.). Furthermore, many systems, as e.g. the LMC and SOLID, rely on fluorescence detection methods that require complex optical systems including radiation sources, lenses and optical filters for the rejection of the excitation wavelength and the selection of the proper analytical signal.

Chemiluminescence detection, in which the photon emitter is brought to its excited state by a chemical reaction, represents a valid alternative to fluorescence methods, eliminating the need to implement the photoexcitation system (Pires et al., 2014; Mirasoli et al., 2014a). Additionally, chemiluminescence detection has been proved to provide superior detectability, as several sources of background and interference found in fluorescence-based assays are avoided, such as light scattering and fluorescent emission from cofactors or sample compounds, that decrease the signal-to-noise ratio and require mitigation (Roda et al., 2016).

In this work, we describe the development of the Planetary Life Explorer with Integrated Analytical Detection and Embedded Sensors (PLEIADES) chip, that integrates on a single glass substrate: 1) an autonomous microfluidic network in which samples and reagents are handled exploiting capillary forces, thus eliminating the need for external pumping units; 2) a set of functionalized detection sites where antibody or aptamer-based binding assays based on chemiluminescent detection will be carried out; 3) an array of thin-film hydrogenated amorphous silicon (a-Si:H) photosensors for the detection of the chemiluminescent signal (Costantini et al., 2016; Mirasoli et al., 2014b). The PLEIADES chip is interfaced with a custom low-noise front-end electronics for the biasing of the photodiode array and the readout of the photocurrents. The front-end electronics provides a digital interface with a computer where a custom Java software performs data

preprocessing, visualization, analysis and storage. To investigate the possibility to detect ATP by means of different luminescent bioassays, we optimized and applied on-chip a bioluminescence luciferase-based assay, a chemiluminescence competitive enzyme immunoassays and an aptamer-based DNA nanoswitch assay.

2. Materials and methods

2.1. Reagents and materials

Adenosine 5'-triphosphate (ATP) disodium salt hydrate (99%), guanosine 5'-triphosphate (GTP), cytidine 5'-triphosphate (CTP), uridine 5'-triphosphate (UTP), hemin from bovine ($\geq 90\%$), trizma hydrochloride, luminol sodium salt, anti-rabbit IgG conjugated to horseradish peroxidase (HRP-IgG), sodium dodecyl sulfate (SDS), formamide, dithiothreitol (DTT), Alconox, bovine serum albumin (BSA), n-propyldimethylchlorosilane, 3-aminopropyltrimethylethoxysilane, N-[ε-maleimidocaproyloxy]sulfo succinimide ester (sulfo-EMCS), and Silane-Prep slides were purchased from Sigma-Aldrich (St Louis, MO). Antibody anti-ATP produced in rabbit and ATP conjugated to ovalbumin (OVA-ATP) were bought from Cloud-Clone Corp (Katy, TX). Chemiluminescent substrate for HRP Supersignal ELISA Femto was purchased from Thermo Fisher Scientific (Waltham, MA). Sodium hydroxide and potassium dihydrogen phosphate were purchased from Carlo Erba Reagents (Milano, Italy). Hydrogen peroxide (30%) was purchased from VWR International (Radnor, PA). DNA sequences purified via high-performance liquid chromatography (HPLC) were purchased from Integrated DNA Technologies (IDT, Skokie, IL). All reagent-grade chemicals were used without further purification. Ultrapure water from Merckmillipore (Billerica, MA) source was used throughout the experiments.

Samples simulating an extract from an assumed soil sample were prepared by spiking with known ATP amounts a water:methanol (80:20, v/v) solution containing 1.5 mg mL^{-1} Polysorbate 80.

All reagents employed for poly 2-(hydroxyethyl methacrylate) (HEMA) were purchased from Aldrich Chemicals. 2-Hydroxyethyl methacrylate (HEMA) was distilled prior to use, whereas the other chemicals were used without further purification. 2-Bromo-2-methylpropionic acid 3-trichlorosilylpropyl ester (BMPTS) was synthesized following a reported procedure (Costantini et al., 2016). Acetone and ethanol 96% (analytical reagent grade) were used without further purification, while toluene was distilled over sodium. The synthesis of the poly(2-hydroxyethyl methacrylate) was performed using a previously reported procedure (Costantini et al., 2015, 2016). The Cell-Titer-Glo Luminescent Cell Viability Assay was purchased from Promega.

2.2. Reference optical instrumentation

Absorbance measurements were performed using a Varian Cary 50Scan UV–Vis spectrophotometer. For optimizing the DNA nanoswitch protocol, chemiluminescence measurements in microtiter plate format were carried out using a Thermo Scientific Luminoskan Ascent luminometer (Thermo Fisher Scientific).

As a reference instrumentation, an ultrasensitive CCD camera (MZ-2PRO from MagZero, Pordenone, Italy), equipped with a thermoelectrically cooled monochrome Sony ICX285 sensor, coupled with an objective and inserted into a light-tight dark box to avoid interference from ambient light, was used to image the chemiluminescence signal from the PLEIADES chip.

2.3. PLEIADES chip

The core of the proposed analytical platform is an innovative lab-on-chip device that integrates on a single glass substrate the microfluidic network for the implementation of the analytical protocols, the

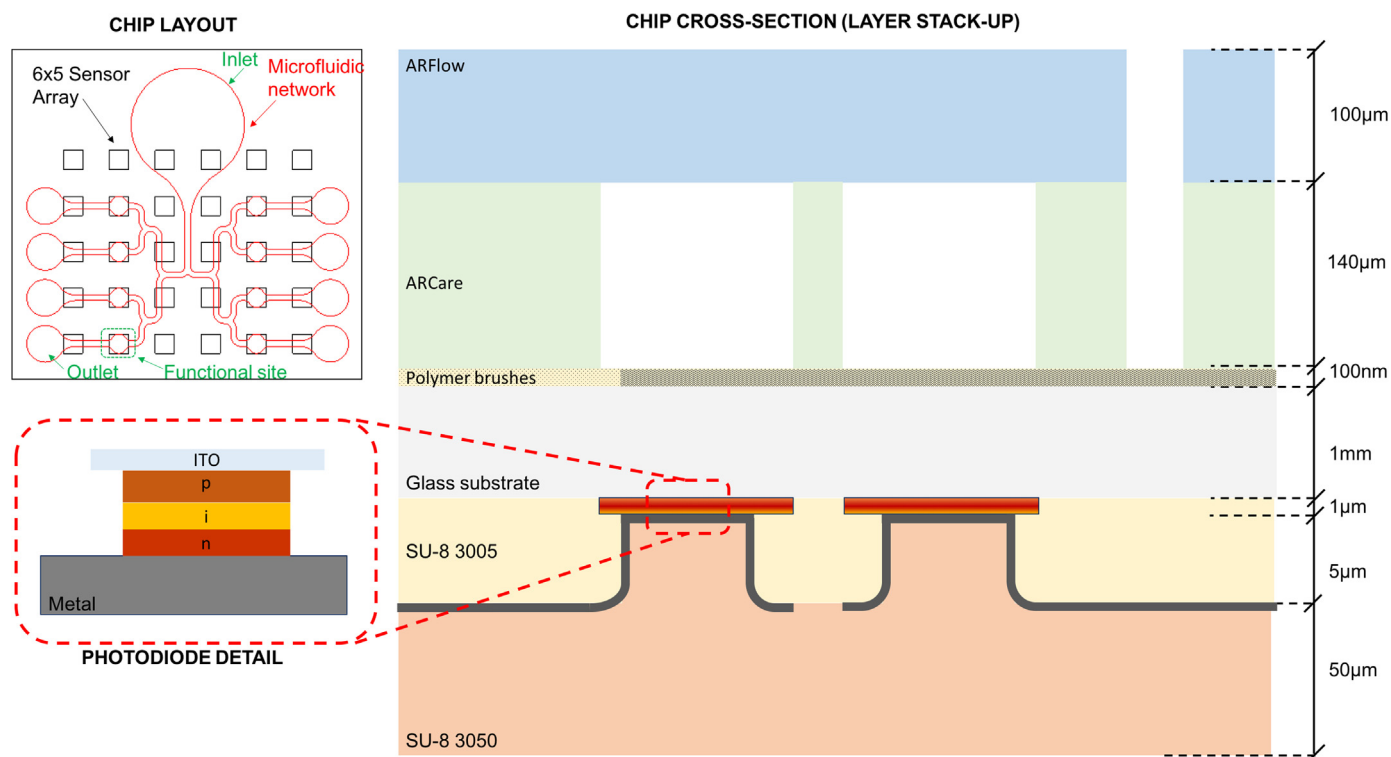

Fig. 1. Schematic view of the PLEIADES chip. Top-left: simplified chip layout view showing the position of the 30 photodiodes (squares) and the shape of the microfluidic network with one inlet and 8 identical branches, each having a functional site and an outlet. Right: cross-section of the chip (not to scale). The thickness of each layer is reported on the right. Bottom-left: detail of the thin-film a-Si:H p-i-n photodiode with transparent contact at the glass side to measure the CL signal coming from the opposite side of the glass.

functionalized surface for the immobilization of the target molecules and an array of thin-film a-Si:H photodiodes for the transduction of the chemiluminescent signal into an electrical signal. The structure of the chip is reported in Fig. 1.

The substrate is a soda-lime glass. The microfluidic network is fabricated using a stack of Pressure Sensitive Adhesives (PSA) from Adhesive Research (ARFlow 93049, ARCare 90106). The microfluidic network has been cut in the PSA layers by means of a cutting plotter (Silhouette Curio). The glass surface functionalization for the final device has been achieved using a layer of PHEMA polymer brushes grown on one side of the glass substrate. The thin-film photodiodes are stacked structures of p-doped, intrinsic and n-doped hydrogenated amorphous silicon (a-Si:H) with transparent indium tin oxide (ITO) bottom contact and metallic (Cr-Al-Cr)-stack as top contact. The a-Si:H layers have been deposited by Plasma Enhanced Chemical Vapor Deposition (PECVD) using a three-chamber ultra-high-vacuum system (Glasstech Solar Incorporation, Denver, Colorado). The 180 nm-thick ITO layer was deposited by a magnetron sputtering physical deposition system from Materials Research Corporation (Orangeburg, NY, USA). The top metal electrode is a three-metal layer stack (30 nm-thick Cr, 150 nm-thick Al, 30 nm-thick Cr) deposited using the same sputtering system. SU-8 (SU-8 305 and SU-8 3050 from Micro Resist Technology GmbH) is used both as interlayer dielectric and final passivation layer.

The fabrication process has been optimized to ensure the compatibility among all the process steps. The high-level sequence of processing steps is the following: 1) fabrication of the array of thin-film photodiodes on one side of the glass substrate (Costantini et al., 2015); 2) growth of the PHEMA polymer brushes layer on the other side of the glass substrate; 3) mounting of the PSA microfluidic network on the PHEMA side of the glass substrate.

Preliminary characterization of the lab-on-chip device has been performed by testing all of its components. Current-voltage characterization and spectral responsivity measurements were performed on the

a-Si:H photodiodes using a setup based on a Keithley 236 Source Measure Unit (SMU), a tungsten light source, a monochromator (model Spex 340E from Jobin-Yvon), an UV-enhanced crystalline silicon diode (model DR 2550–2BNC from Hamamatsu) used as reference, a beam-splitter and focusing optics (from Melles-Griot).

Several versions of the microfluidic network have been designed and tested to implement all the features needed for the execution of multi-step analytical protocols with good reproducibility and reliability. The tests have been performed by filling the network with colored buffer solutions that mimic the real solutions of the actual experimental protocols, and by filming the capillary filling of the network with a camera.

2.4. Front-end electronics

The front-end electronics (Fig. 2) enables the simultaneous acquisition of all the on-chip sensors of the PLEIADES chip. The 32-channel front-end electronic board has been developed for this project starting from a previous 8-channel design (Nascetti et al., 2014). The board includes the following sections: 1) a card edge connector (Samtec MB1–150-S-02-SL) as physical interface with the lab-on-chip; 2) a low-noise analog section including the current readout circuit (DDC118 from Texas Instruments) and the bias voltage supply circuit (AD5665 digital-to-analog converter from Analog Devices with LM7321 op-amp in buffer configuration from Texas Instruments) for the operation of the array and the digitization of the acquired signals; 3) a digital section (PIC18F4550 from Microchip) for timing and control of the analog part and for the interfacing (Universal Serial Bus, USB) with a computer. The front-end electronics is enclosed in a light-tight 5-mm thick aluminum box to ensure shielding from electromagnetic interferences (EMI) and from ambient light. A custom Java Graphical User Interface (GUI) has been developed to access all the board functionalities (including calibration and experimental protocol execution) and for real-time data

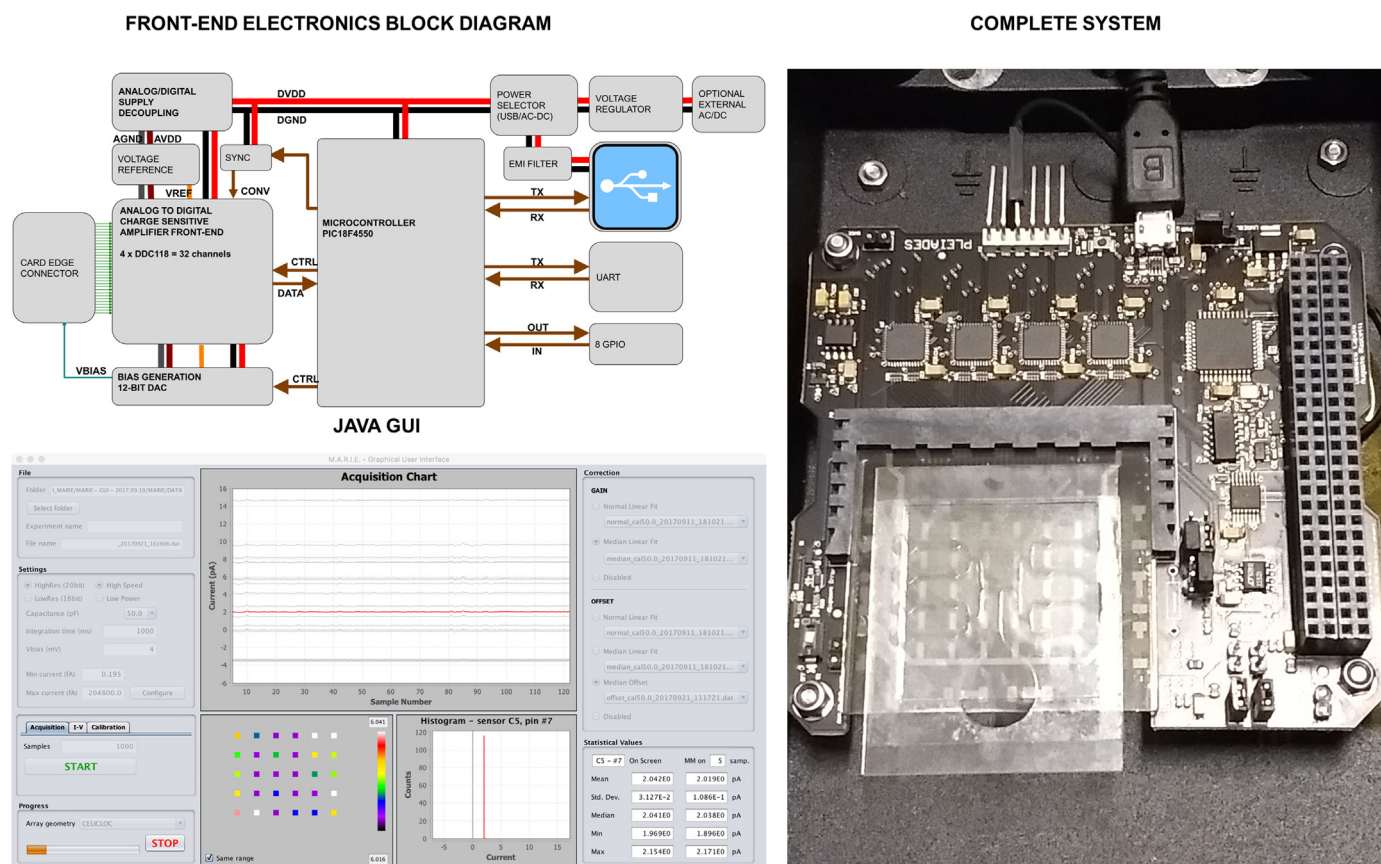

Fig. 2. Top-left: block diagram of the electronic front-end showing its main components and connections. Bottom-left: screenshot of the Java Graphical User Interface acquired during a test experiment. Right: picture of the whole system inside the black metallic shielding box with the PLEIADES chip attached to the card edge connector. The PLEIADES front-end board has PC-104 format and has been designed according to electronics reliability guidelines.

pre-processing, visualization, statistical analysis and storage (Fig. 2). Fig. 2 also shows the complete PLEIADES system.

2.5. Bioassays

2.5.1. Competitive immunoassay

Once the PHEMA polymer brushes layer had grown on the glass substrate, 1 μL -spots of OVA-ATP (0.01 mg mL^{-1} in 50 mM borate buffer, pH 9.6, containing 0.1% (v/v) glycerol) were deposited onto the activated glass surface and incubated for 1 h at room temperature.

After rinsing the chip with abundant PBS and drying with nitrogen flow, the top liner of the ARcare layer was removed and the chip was sealed with the ARFlow layer. The microfluidic network was then filled with a solution of blocking buffer (10 mM HEPES, 5 mM KCl, 120 mM NaCl, 10 mM CaCl_2 , pH 7, 2% BSA), and incubated for 2 h before rinsing with ultrapure water. The channels were then emptied using a cellulose pad (Whatman CF7, Whatman plc, Maidstone, UK) at the outlets and, if needed, also at the inlet. At this point the chip was ready to be stored at 4 °C prior to the use. For performing the assay, the double-sided PSA layer had to be mounted on the glass substrate on the opposite side with respect to the photosensor array taking care to leave accessible the microfluidic network for the injection of sample and reagents.

For starting the immunoassay, a solution containing the sample and the anti-ATP antibody diluted 1:500 (v/v) in PBS was injected at the eight inlets and incubated for 30 min. After a washing step performed as the one after saturation, a solution containing HRP-IgG diluted 1:2000 (v/v) in PBS was loaded (30 min of incubation). After rinsing with PBS to remove unbound HRP-IgG, the cellulose pad was removed, and the fluidic channels were filled with Super Signal ELISA Femto substrate for

HRP. The detection of the chemiluminescence signal was performed by measuring the photocurrents of the on-chip sensors after enclosing the whole system into a dark box equipped with a CCD camera, for monitoring the signal with the a-Si:H photosensors and the CCD simultaneously. Calibration curves were generated in a concentration range comprised between 10 nM and 20 μM ATP. Each point of the calibration curve corresponds to the plateau value of photocurrent measured during the entire luminescent reaction kinetics averaged over three independent measurements. The reported limits of detection (LOD) have been calculated as the ATP concentration whose signal corresponds to three times the standard deviation of the blank signal, which is measured in the absence of the target analyte.

2.5.2. DNA nanoswitch

The oligonucleotides were used as provided and diluted in pH 7.5, 50 mM of phosphate buffer solution to give stock solutions of 100 μM . The sequences of the DNA-nanoswitches regulated by ATP are as follows:

Switch #1: 5'-ACCTGGGGGAGTAT AACC TGC GGAGGAAGGT ATT GGGT GGGTTGGGTGGGT-3'
 Switch #2: 5'-ACCTGGGGGAGTAT AACCC TGC GGAGGAAGGT TTTGGGT GGGTTGGGTGGGT-3'
 Switch #3: 5'-ACCTGGGGGAGTATCCAACCC TGC GGAGGAAGGT TTTGGGTGGGTGGGTGGGT-3'
 Control G-quadruplex: 5'-GGGTGGGTTGGGTGGGT-3'
 Control ATP aptamer: 5'-ACCTGGGGGAGTATTGC GGAGGAAGGT -3'

In the sequences above the underlined bases represent the stem

portion of the “non-binding” state, while the italic bases represent the ATP recognition element and the stem of the “bound” state. The DNA sequence also contains a 5′ linker with a terminal SH group, used for grafting the nanoswitch to the glass surface of PLEIADES chip through covalent bonding.

Thiol-modified DNA nanoswitch #3 was immobilized on glass following a published procedure (Shircliff et al., 2013). Upon cleaning with 1% Alconox (w/v) in deionized water, silanized microscope glass slides were treated with 1 mM sulfo-NHS in 0.1 M sodium phosphate buffer, pH 7.5, for 40 min at room temperature, then washed with sodium phosphate buffer and dried in on nitrogen flow. Thiol-modified DNA sequences, which were protected with a disulfide bond by the vendor, were reduced to the sulfhydryl active form by incubating the sample with 0.1 M DTT in sodium phosphate buffer, pH 8.4, for 1 h at room temperature. Then, 1 μ L of the probe was pipetted onto modified substrates and allowed to incubate for 2 h at room temperature in a humid chamber. Finally, the glass surface was treated with a pre-hybridization buffer (0.1% SDS, 0.1 mg mL⁻¹ BSA) for 1 h at 42 °C to prevent nonspecific adsorption. After washing and drying under nitrogen, the glass slides were stored at 4 °C until use.

For performing the assay, the glass slide was coupled with the PSA microfluidic network and then integrated with the photosensors array. The assay was started by injecting the sample which contains ATP; upon 2 h incubation at room temperature and emptying the channels using adsorbent cellulose pad, hemin was added and incubated for 1 h at room temperature to form the hemin/G-quadruplex structures. Finally, after a washing step, a solution containing luminol and hydrogen peroxide was used for filling the channels and the chemiluminescence signals were acquired using the configuration described for the competitive immunoassay.

2.5.3. Bioluminescence luciferase assay

Disposable multiwell cartridges with integrated a-Si:H photosensors were obtained by coupling with the glass support a 10-mm-thick black PDMS unit bearing holes aligned with the photosensors array, as previously described (Mirasoli et al., 2014b). In this configuration each hole represents a microwell in which the bioluminescence reaction occurs, while the corresponding photosensor monitors the photons emission. The assay was started by depositing in each microwell 5 μ L of the solution containing ATP (calibration curve was generated into the concentration range 1 μ M–10 nM) and then an equal volume of Cell-Titer-Glo® Reagent was added. The obtained mixture was incubated 10 min at room temperature. After enclosing the integrated multiwell cartridge into a dark box (also equipped with a CCD camera for reference parallel measurements), the luminescent signal was monitored with the a-Si:H photosensors, through consecutive acquisitions for 10 min. Each point of the calibration curve corresponds to the plateau value of photocurrent measured during the entire luminescent reaction kinetics averaged over three independent measurements. The reported LOD has been calculated as the ATP concentration whose signal corresponds to three times the standard deviation of the blank signal, which is the signal measured when the BL cocktail was poured in a well without the analyte.

3. Results and discussion

3.1. PLEIADES chip design

The PLEIADES lab-on-chip includes a set of 30 photodiodes arranged in 5 rows of 6 elements each. Each photodiode is 2 × 2 mm² and the pitch of the array is 5 mm in both directions. The microfluidic network has been designed according to the following requirements: 1) multiple samples should be analyzed in parallel on the same chip: different samples must therefore be loaded in correspondence of different sensors and must not interact with each other; 2) washing buffer and reagents should be flowed on each functional site; in particular, fresh

CL reagents should arrive on each functional site (i.e. the CL reagents that flowed on the site where a given sample was loaded should not flow on the sites where other samples have been loaded: this is to prevent the depletion of the CL reagents and the consequent change in the signal intensity); 3) the microfluidic network should operate by autonomous capillary flow without the need of external pumping devices.

The requirements listed above have been met by a capillary network having a single inlet followed by successive splitting channels leading to eight identical branches each of them with a reaction site and an outlet pad. In this case only eight out of the thirty available photodiodes are used to monitor the reaction sites; the remaining sensors were used to monitor the residual background radiation, if any, and the background spontaneous luminescence of the chemiluminescence reagents, to define the zero-level of the analytical signal. The microfluidic network described above is cut in the double-sided PSA layer (ARcare 90106) and is sealed with the single-sided PSA (ARFlow 93049).

3.2. PLEIADES chip operation

The life-cycle of the proposed lab-on-chip device can be divided in three main phases: the fabrication phase, the preparation phase and the operation phase. Referring to the cycle of a planetary exploration mission, the first two steps would be made on ground in the lab prior to the launch into space, while the last one would be executed once landed on the target body. These aspects have been considered when defining the protocols reported in the following paragraphs.

The fabrication phase includes the fabrication of the photodiode array, the functionalization of the glass surface (growth of the PHEMA polymer brushes layer or of the aminosilane film) and the preparation of the PSA microfluidic layers with the desktop cutting plotter. This phase ends with the mounting of the double-sided PSA layer on the glass substrate on the opposite side with respect to the photosensor array. At this point the top protective liner is left in place and the microfluidic network remains accessible for the next phase.

Regardless of the type of implemented assay, the preparation phase consists of immobilization of the biospecific recognition molecules at the functional sites defined in the microfluidic network aligned with the photodiode array. The biofunctionalized chip can be stored at 4 °C prior to use.

The operation phase comprises the addition and incubation of the sample and the addition and incubation of suitable reagents; it can include washing steps depending on the protocol involved. Up to eight different samples can be loaded in the network by pipetting 1 μ L of each sample at the eight outlets of the microfluidic network. The sample moves backwards inside the microfluidic channels by autonomous capillary flow, then stops just after having filled the functional site that is present on each of the eight branches of the network. Labeled reagents (HRP-IgG or hemin) are loaded employing the same procedure. Although this step could be performed by inserting the solution at the inlet of the microfluidic network, the selected procedure implies a lower consumption of the labeled reagents and limits the risk of non-specific adsorption along the microfluidic network that would lead to disturbing non-specific background signals. All washings are performed through a rinsing flow, achieved by approaching a piece of adsorbent cellulose pad at the eight outlets of the microfluidic network and repeatedly filling the inlet reservoir with rinsing solution. Chemiluminescence reagents are loaded at the common inlet of the chip and the photon emission is concurrently detected by measuring the photocurrents of the on-chip sensors.

The fabrication, preparation and operation protocol described above highlights some of the advantages of the proposed lab-on-chip device, such as high system robustness, limited need for ancillary hardware and reduced power consumption. The on-chip photosensors allow a perfect optical coupling and higher light collection angle with respect to off-chip detectors, such as CCDs. This implies a more efficient

photons collection and thus lower LOD values. In addition, the room-temperature bonding procedure for the attachment of the PSA microfluidic network significantly simplifies the immobilization phase that is performed prior to the sealing of the chip. This fact implies, for example, the possibility to immobilize different biospecific probes in different sites to implement multi-parametric assays. Moreover, the use of PHEMA brushes as anchor for the biospecific probes, e.g., OVA-ATP, increases the specific surface available for the biorecognition event in the functional sites leading to an increase of the system sensitivity (Costantini et al., 2010).

3.3. PLEIADES chip characterization

For the preliminary experimental validation of the proposed system, it was decided to fabricate the lab-on-chip using two different glass substrates: one hosting the a-Si:H photodiodes and the other with the functionalized surface and the microfluidic network. No changes have been done in the fabrication protocol, which is therefore identical to that used to produce the monolithic exemplars of the lab-on-chip. This choice was taken to focus on the analytical performances and reduce the number of variables that may affect the results. In particular, with the abovementioned approach, the same array of photodiodes has been used throughout an entire series of experiments making the achieved results directly comparable to each other. To ensure optimal optical coupling an optical index matching oil was used between the two glass substrates. This technique proved to deliver results that closely match those achieved with monolithic devices.

The results of the preliminary characterization of the sensors showed dark-current density around 10^{-10} A/cm² measured at 10 mV reverse-bias voltage and responsivity values around 250 mA/W at 465 nm with the same bias level. The overall system noise has been measured in the practical operation conditions sampling the current of the photodiode in dark conditions before the last step of the protocol, namely before the pipetting of the chemiluminescence reagents at the microfluidic inlet. An average noise current level of 50 fA has been achieved working with a full-scale signal range of 1 nA and a data rate of 5 samples/s.

After the preliminary system characterization, several experiments have been performed as reported in the next paragraphs.

3.4. Competitive immunoassay for ATP detection

Exploiting the PLEIADES chip, we developed an indirect competitive ELISA method for the detection of ATP, based on the competition of ATP present in the sample and ATP conjugated to ovalbumin immobilized into the microchannel for binding anti-ATP primary antibody. The detection was performed using a secondary HRP-labeled antibody and adding the proper CL substrate. All the experimental parameters, including reagents composition and incubation times and

conditions have been optimized. A typical calibration curve is reported in Fig. 3B, while Fig. S1 of Supplementary material reports the signals obtained for different concentrations of ATP in a range comprised between 0.3 nM and 20 μ M. From these data, a limit of detection of 60 nM was found, confirming the data obtained using an ultrasensitive cooled CCD camera used as a reference detector. This detectability is comparable with that obtained employing a commercial bioluminescence luciferase-based assay.

As mentioned above, the relatively high stability of free and grafted antibodies exposed to cosmic rays simulating the conditions of a mission to Mars has been assessed (Baqué et al., 2017), provided that appropriate design features (e.g. a surface density of antibodies much larger than the expected proton fluency across the chip) are adopted. However, ELISA-based methods employ enzyme labels, that pose additional conservation issues, including the requirement for low temperature storage conditions (typically 2–8 °C) and a limited shelf life. Several additives can be added to the storing solution to significantly increase long-term enzymes stability (Jahanshahi-Anbuhi et al., 2016) and, as an alternative, novel artificial catalytic systems could be used for replacing traditional enzymes, such as DNAzymes. For example, the recently proposed heme synthetic proteins, named mimochromes, can mimic the peroxidase activity with improved stability and efficiency (Vitale et al., 2015) and they will be explored as a high potential tool to be exploited as label in ELISA-based method for extra-terrestrial applications.

3.5. DNA nanoswitch

A structure-switching aptasensor exploiting ATP-induced hemin-DNAzyme catalytic activity (Adornetto et al., 2015) for generating a chemiluminescent signal was developed for its implementation on the PLEIADES chip.

The assay principle, shown in Fig. 4a, is based on a stem-loop DNA-nanoswitch that can adopt two exclusive conformations: “non-binding conformation” containing a stem domain and a “binding-competent” conformation containing a duplex stem (blue stem, Fig. 4a) recognized by the specific target analyte ATP. The binding of ATP pushes the conformational equilibrium towards the latter “bound” state to allow the hemin/G-quadruplex structuring. The incorporation of hemin into the resulting G-quadruplex ATP-nanoswitch aptamer complex yields an active HRP-mimicking DNAzyme, which generates a chemiluminescence signal in the presence of H₂O₂/luminol proportional to ATP concentration.

We designed three variants of ATP-regulated DNA-nanoswitches, each having the same binding domain for ATP with different “binding-competent” state stability. Control G-quadruplex sequence was employed to predict the signal/noise ratio of G-quadruplex structure/hemin, while control ATP aptamer sequence was employed to investigate non-specific interactions between ATP aptamer and hemin,

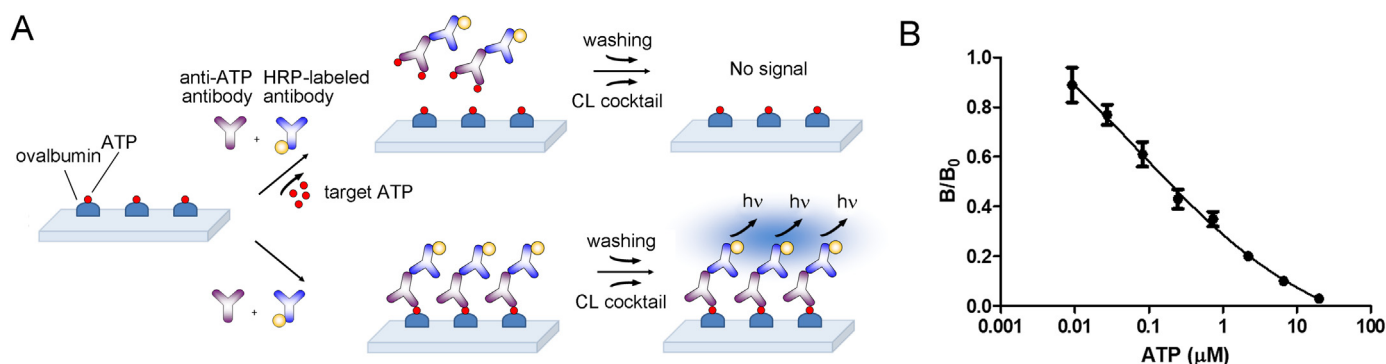

Fig. 3. : (A) Scheme of the competitive immunoassay: top scheme represents the analysis of a sample containing a high amount of ATP, while bottom scheme represents the analysis of a sample containing no ATP; (B) Calibration curve.

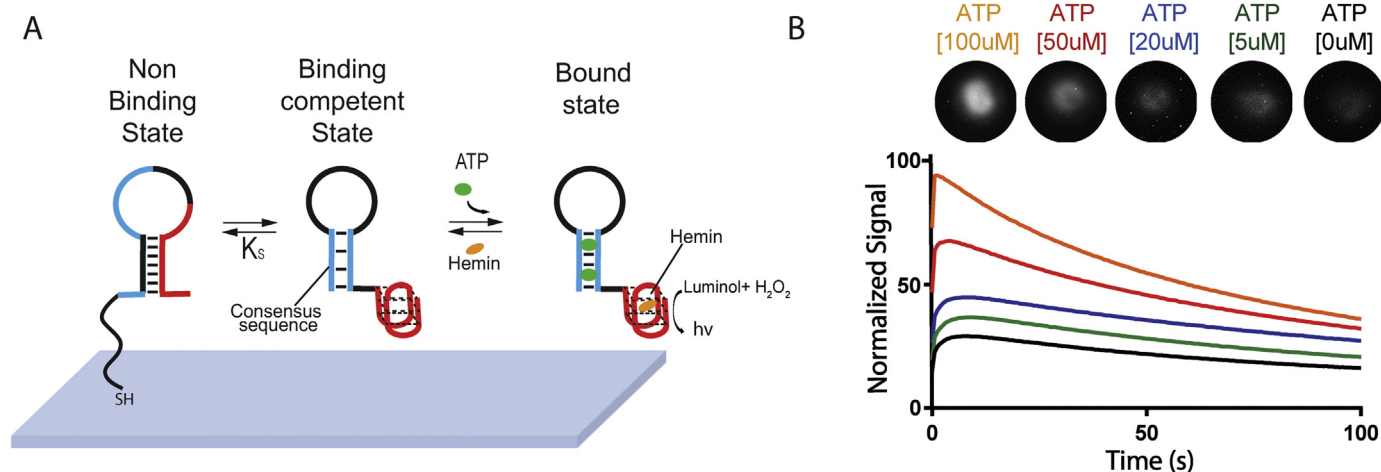

Fig. 4. : (A) ATP-regulated DNA-nanoswitches coexist in two mutually exclusive stem-loop conformations, i.e. “Non-Binding” and “Binding-competent”. The binding of ATP pushes this conformational equilibrium towards the “Bound” state, thus triggering the hemin/G-quadruplex structuring. (B) Chemiluminescence nanoswitch #3 spectra generated by the hemin/G-quadruplex aptamer ATP complex, in the presence of H_2O_2 /luminol and different concentrations of ATP. As the concentration of ATP is elevated, the chemiluminescence is intensified, consistent with the higher content of the assembled DNAzyme G-quadruplex structure.

eventually caused by G-quadruplex ATP aptamer structure.

Firstly, a characterization of the DNA-nanoswitches was performed in solution in a conventional microtiter plate format. We evaluated the different DNA-nanoswitches affinity, producing chemiluminescence binding curves in the presence of increasing ATP concentrations. We found that DNA-nanoswitch # 3 displayed the highest signal intensity and affinity, as shown in Fig. 5a. We therefore selected switch #3 to further characterize the kinetics of the system. We observed an increase in activation with increasing ATP, with a signal increase of 160% observed for 100 μM ATP, consistent with the higher content of the assembled DNAzyme G-quadruplex structure (Fig. 5b). In contrast, the DNAzyme remains inactive when challenged with other non-specific targets, such as 100 μM CTP, GTP, and UTP (Fig. 5c).

Subsequently, the DNA-nanoswitch #3 was immobilized onto the PLEIADES chip for performing the on-chip assay. Following a published procedure (Shircliff et al., 2013), an inhomogeneous aminosilane film was produced on glass, followed by grafting by a maleimide-terminated crosslinker to provide a reactive site for the thiol-modified DNA covalent attachment. We employed this protocol, as it was reported to provide the best compromise in terms of immobilized DNA probe density, still avoiding excessive steric hindrance that would prevent proper DNA folding.

As shown in Fig. 4b, we observed an increase in activation with increasing ATP and an EC_{50} (the effector concentration at which 50% activation is observed) of $5 \pm 0.8 \mu\text{M}$ (Fig. 4b, red line), consistent with the dissociation constant ($6 \pm 3 \mu\text{M}$) reported for the ATP binding 27-mer aptamer employed in this work (Huizenga and Szostak, 1995).

The present study has demonstrated that G-quadruplex DNA-nanoswitches can recognize different ATP concentrations and turn into catalytically active DNAzymes that generate chemiluminescence in the presence of H_2O_2 /luminol. Specifically, nanoswitch #3 can be used as a potential biosensor to detect the life marker ATP through DNAzyme-like catalytic activity. In the future, to reach lower limits of detection, a target recycling-induced amplification mechanism will be explored (Xie et al., 2017).

3.6. Bioluminescence luciferase assay

Since the mid-1960s bioluminescent luciferase/luciferin-based assay was widely exploited thanks to its high sensitivity, selectivity, rapidity (results are obtained in less than 15 min) and relative ease of application. The assay uses firefly luciferase to catalyze the following luciferin oxidation reaction:

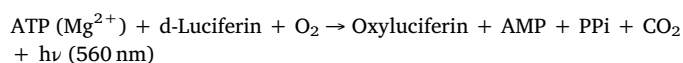

When ATP is the limiting factor in the reaction, the amount of light produced is proportional to the ATP concentration. However, the *Photinus pyralis* luciferase traditionally employed in this assay suffers from relatively low stability in vitro and is sensitive to temperature and to the chemical environment, such as pH and detergents, thus limiting assay robustness. Therefore, the assay was conducted employing the CellTiter-Glo® Reagent, which contains a mutated form of *Photuris pennsylvanica* luciferase displaying increased chemical and thermostability. With this approach, a single reagent containing all the elements necessary for cell lysis and bioluminescence measurement of ATP could be dispensed in the wells of the cartridge, ready to be reconstituted and to start the assay simply upon sample addition.

As the commercial kit is performed in solution, the assay was performed in a microwell format, to ensure rapid reagents mixing and high photons collection efficiency.

The protocol was adapted to a 10 μL total volume analysis. By integrating the measured bioluminescence signal obtained at different ATP concentrations, a calibration curve was obtained (Fig. S2 of Supplementary material), displaying a LOD of 40 nM, which was in the same order of magnitude of that obtained using a bench-top luminometer (10 nM). This result is promising when considering the remarkable decrease in the total volume analysis and the ease-of-use of the portable device with respect to a bench top instrumentation.

The field applicability of the method could be further improved exploiting luciferases displaying remarkably high stability features allowing to work even at extreme conditions (up to 50 °C for more than 1 h) (Kajiyama and Nakano, 1994). In addition, future studies will be performed to immobilize enzymes within the channels of the PLEIADES chip, thus enabling to perform assays in a microfluidic flow regimen.

3.7. Applicability of the PLEIADES chip for astrobiology

The PLEIADES chip has been specifically designed in view of its future possible application in extraterrestrial exploration missions. The structure of the chip, with the monolithic integration of sensors and detection sites on the same glass substrate, provides compact size, minimal weight, high photons collection efficiency, intrinsic mechanical stability avoiding the risk of misalignment between sensors and reaction sites due to e.g. vibrations or shocks, simplified chip fabrication and handling, higher system robustness and higher overall

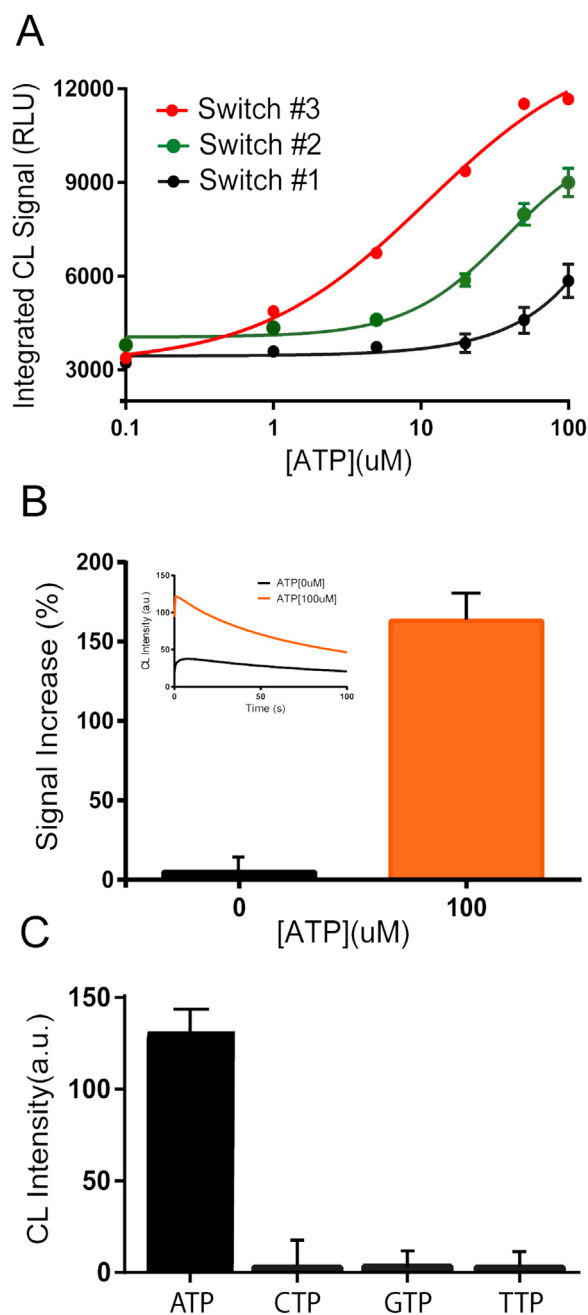

Fig. 5. : (A) chemiluminescence binding curves of DNA-nanoswitches variants (#1, #2, #3) in the presence of increasing ATP concentrations. (B) For nanoswitch #3 we observed an increase in activation of 160%. (C) The DNAzyme remains inactive when challenged with other non-specific targets. Incubation with 100 μM of different nucleoside triphosphates, for example CTP, GTP, TTP, does not produce any significant signal increase.

reliability (e.g. reduces risk of sensor damages due to unwanted leaks from the microfluidic network). Additionally, the absence of pumping devices or radiation sources significantly reduces the overall power consumption and reduces the risk of electromagnetic interferences due to electrically actuated devices as pumps, valves or switches. The only electronic board required is the sensor front-end electronics whose power consumption is well below 1 W.

System complexity is highly reduced, due to the limited need for ancillary hardware. As an autonomously-driven capillary flow is employed, microfluidic pumps and pressure-tight fluidic joints are not necessary. Similarly, chemiluminescence detection ensures high

sensitivity and high specificity without the need of external radiation sources and radiation filters. Finally, the use of one photodiode for each functional site ensures optimal signal-to-noise ratio as well as a limited data budget, which can be three orders of magnitude lower than that of equivalent experiments performed using a CCD camera while ensuring similar analytical performances, thus providing faster data processing and reduced storage and transmission bandwidth requirements. Reduced system weight, size, complexity, power consumption and data budget are aspects of fundamental importance for a space mission, making the proposed system extremely attractive for application in this field.

One of the main critical issues for analytical payloads applied in astrobiology is the long-term stability of reagents and materials under space conditions, in particular cosmic radiations. The PLEIADES chip is equipped with a-Si:H photosensors, which ensure superior performances in terms of radiation hardness with respect to other technologies. As concerns reagents, while the stability of antibodies (Baqué et al., 2017) and aptamers (Baqué et al., 2011) has been assessed in relevant environments, all other reagents still need to be investigated (Court et al., 2014). Further work is required to investigate and improve the stability of enzymes, taking advantage of currently available solutions for long-term enzyme conservation (Jahanshahi-Anbuihi et al., 2016) or exploiting synthetic enzyme mimics. Despite this, the possibility to employ enzyme-based assays for searching life markers is worth being explored, since it would expand the range of possible targets to several molecules for which avid antibodies are not available, while enzyme assays are well-established, such as cholesterol, NAD(P), phosphoenolpyruvate, porphyrins. Provided that suitable measures are adopted to ensure long-term enzymes stability and to control key factors, such as temperature and pH during the assay, several relevant analytes could be thus targeted taking advantage of high enzyme turnover and signal amplification that can lead to highly sensitive assays.

4. Conclusions

The primary scientific objective of the PLEIADES chip is to detect a range of biomolecules in a liquid aqueous sample, obtained upon extraction of a soil or crushed rock sample or upon melting of an ice sample. The PLEIADES chip has been designed as an integrated chip containing all the elements for performing the analytical procedure. In a complete analytical system for in situ analysis upon landing on a celestial body, the chip shall be accompanied by some ancillary instrumentation, such as a temperature control system, a sample preparation system and an automated pipetting unit for delivering the samples and the reagents to the inlets of the autonomous capillary network. In addition, suitable protection from cosmic radiations and temperature excursions shall be provided during the journey through the Solar System.

Besides the compact size and the minimal weight, the monolithic integration of sensors, detection sites and microfluidics on the same glass substrate provides several positive features for space applications of the PLEIADES chip, such as intrinsic mechanical stability, reduced overall power consumption and data budget.

Different chemiluminescence bioassays were implemented on the PLEIADES chip to demonstrate its versatile applicability. In the future, multiplexed assays will be developed and a full laboratory validation with simulated samples will be performed.

Acknowledgements

The project PLEIADES (Planetary Life Explorer with Integrated Analytical Detection and Embedded Sensors) was supported by the Italian Space Agency (ASI) (Accordo n. 2015-037-R.O).

Authors contribution

AN: high-level system design, readout electronics (HW/SW) design, Principal Investigator of PLEIADES project. MM: design of luminescence bioassays, coordination of experimental activities for bioassays development and their implementation into the chip, Co-Principal Investigator of PLEIADES project. EM: experimental set-up of switching ATP-binding aptamers. MZ: design and optimization of the immunoassay and bioluminescence assay for ATP detection. FC: surface functionalization, analytical protocol setup. AP: design of structure-switching ATP-binding aptamers. LI: microfluidics design, fabrication and test. NL: sensors characterization. DC: sensor array design and fabrication, experimental setup. GC: sensor array design, fabrication process design. SP: Italian Space Agency representative. AR: supervision and coordination of project activities concerning luminescence bioassays.

Appendix A. Supporting information

Supplementary data associated with this article can be found in the online version at doi:10.1016/j.bios.2018.08.056.

References

- Adornetto, G., Porchetta, A., Palleschi, G., Plaxco, K.W., Ricci, F., 2015. *Chem. Sci.* 6, 3692–3696.
- Baqué, M., Dobrijevic, M., Le Postollec, A., Moreau, T., Faye, C., Vigier, F., Incerti, S., Coussot, G., Caron, J., Vandenabeele-Trambouze, O., 2017. *Int. J. Astrobiol.* 16, 82–90.
- Baqué, M., Le Postollec, A., Ravelet, C., Peyrin, E., Coussot, G., Desvignes, I., Incerti, S., Moretto, P., Dobrijevic, M., Vandenabeele-Trambouze, O., 2011. *Astrobiology* 11, 207–211.
- Court, R.W., Sims, M.R., Cullen, D.C., Sephton, M.A., 2014. *Astrobiology* 14, 733–752.
- Costantini, F., Benetti, E.M., Reinhoudt, D.N., Huskens, J., Vancso, G.J., Verboom, W., 2010. *Lab Chip* 10, 3407–3412.
- Costantini, F., Sberna, C., Petrucci, G., Manetti, C., DeCesare, G., Nascetti, A., Caputo, D., 2015. *Sens. Biosens. Res.* 6, 51–58.
- Costantini, F., Sberna, C., Petrucci, G., Reverberi, M., Domenici, F., Fanelli, C., Manetti, C., de Cesare, G., Nascetti, A., De Rosa, M., Caputo, D., 2016. *Sens. Actuator B-Chem.* 230, 31–39.
- Eigenbrode, J.L., Summons, R.E., Steele, A., Freissinet, C., Millan, M., Navarro-González, R., Sutter, B., McAdam, A.C., Franz, H.B., Glavin, D.P., Archer Jr., P.D., Mahaffy, P.R., Conrad, P.G., Hurowitz, J.A., Grotzinger, J.P., Gupta, S., Ming, D.W., Sumner, D.Y., Szopa, C., Malespin, C., Buch, A., Coll, P., 2018. *Science* 360, 1096–1101.
- Ellington, A.D., Szostak, J.W., 1990. *Nature* 346, 818–822.
- Huizenga, D.E., Szostak, J.W., 1995. *Biochemistry* 34, 656–665.
- Jahanshahi-Anbuhi, S., Kannan, B., Leung, V., Pennings, K., Liu, M., Carrasquilla, C., White, D., Li, Y.F., Pelton, R.H., Brennan, J.D., Filipe, C.D.M., 2016. *Chem. Sci.* 7, 2342–2346.
- Kajiyama, N., Nakano, E., 1994. *Biosci. Biotechnol. Biochem.* 58, 1170–1171.
- Ma, D.L., Wang, W.H., Mao, Z.F., Kang, T.S., Han, Q.B., Chan, P.W.H., Leung, C.H., 2017. *ChemPlusChem* 82, 8–17.
- Mirasoli, M., Guardigli, M., Michelini, E., Roda, A., 2014a. *J. Pharm. Biomed. Anal.* 87, 36–52.
- Mirasoli, M., Nascetti, A., Caputo, D., Zangheri, M., Scipinotti, R., Cevenini, L., de Cesare, G., Roda, A., 2014b. *Anal. Bioanal. Chem.* 406, 5645–5656.
- Mohammed, M.I., Haswell, S., Gibson, I., 2015. *Procedia Technol.* 20, 54–59.
- Moreno-Paz, M., Gomez-Cifuentes, A., Ruiz-Bermejo, M., Hofstetter, O., Maquieira, A., Manchado, J.M., Morais, S., Sephton, M.A., Niessner, R., Knopp, D., Parro, V., 2018. *Astrobiology*. <https://doi.org/10.1089/ast.2017.1747>.
- Nascetti, A., Colonia, G., Caputo, D., Tavernelli, M., Placidi, P., Scorzoni, A., de Cesare, G., 2014. *Procedia Eng.* 87, 1577–1580.
- Parnell, J., Cullen, D., Sims, M.R., Bowden, S., Cockell, C.S., Court, R., Ehrenfreund, P., Gaubert, F., Grant, W., Parro, V., Rohmer, M., Sephton, M., Stan-Lotter, H., Steele, A., Toporski, J., Vago, J., 2007. *Astrobiology* 7, 578–604.
- Parro, V., de Diego-Castilla, G., Rodriguez-Manfredi, J.A., Rivas, L.A., Blanco-Lopez, Y., Sebastian, E., Romeral, J., Compostizo, C., Herrero, P.L., Garcia-Marin, A., Moreno-Paz, M., Garcia-Villadangos, M., Cruz-Gil, P., Peinado, V., Martin-Soler, J., Perez-Mercader, J., Gomez-Elvira, J., 2011. *Astrobiology* 11, 15–28.
- Pires, N.M.M., Dong, T., Hanke, U., Hoivik, N., 2014. *Sensors* 14, 15458–15479.
- Pointot, P., Geffroy-Rodier, C., 2015. *TRAC-Trends Anal. Chem.* 65, 1–12.
- Roda, A., Mirasoli, M., Guardigli, M., Zangheri, M., Caliceti, C., Calabria, D., Simoni, P., 2018. *Biosens. Bioelectron.* 111, 18–26.
- Roda, A., Mirasoli, M., Michelini, E., Di Fusco, M., Zangheri, M., Cevenini, L., Roda, B., Simoni, P., 2016. *Biosens. Bioelectron.* 76, 164–179.
- Sephton, M.A., Sims, M.R., Court, R.W., Luong, D., Cullen, D.C., 2013. *Planet. Sp. Sci.* 86, 66–74.
- Shircliff, R.A., Stradins, P., Moutinho, H., Fennell, J., Ghirardi, M.L., Cowley, S.W., Branz, H.M., Martin, I.T., 2013. *Langmuir* 29, 4057–4067.
- Sims, M.R., Cullen, D.C., Rix, C.S., Buckley, A., Derveni, M., Evans, D., Garcia-Con, L.M., Rhodes, A., Rato, C.C., Stefinovic, M., Sephton, M.A., Court, R.W., Bulloch, C., Kitchingman, I., Ali, Z., Pullan, D., Holt, J., Blake, O., Sykes, J., Samara-Ratna, P., Canali, M., Borst, G., Leeuwis, H., Prak, A., Norfini, A., Geraci, E., Tavanti, M., Brucato, J., Holm, N., 2012. *Planet. Sp. Sci.* 72, 129–137.
- Tuerk, C., Gold, L., 1990. *Science* 249, 505–510.
- Vitale, R., Lista, L., Cerrone, C., Caserta, G., Chino, M., Maglio, O., Nastro, F., Pavone, V., Lombardi, A., 2015. *Org. Biomol. Chem.* 13, 4859–4868.
- Xie, M.H., Zhang, K., Zhu, F.F., Wu, H., Zou, P., 2017. *RSC Adv.* 7, 50420–50424.